

# Linear Motor Driven high-speed, high-precision tables

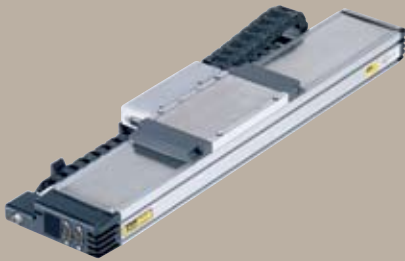

Positioning systems needed for many of today's high-technology applications must satisfy an ever-increasing demand for high throughput and the need for extreme precision. Semiconductor, fiber optics, computer peripherals, metrology, solar scribing, digital printing, and other high-end industries require positioning systems which demonstrate quick response, high acceleration, high velocity, and fast settling time, in conjunction with micron and submicron level positioning. Parker's linear motor product group is designed to satisfy this attribute combination of performance and precision. Products and systems in this section feature advanced direct-drive technology, which enables payloads to be directly driven by highly efficient brushless servo motors.

## Contents

<b>14-15</b>	Overview
<b>16</b>	<b>Specifications</b>
<b>17</b>	Cable Management
<b>18</b>	Digital Drive Options
<b>19</b>	Cleanroom Option
<b>20</b>	404LXR Dimensions
<b>21</b>	404LXR Ordering Information
<b>22</b>	406LXR Dimensions
<b>23</b>	406LXR Ordering Information
<b>24</b>	412LXR Dimensions
<b>25</b>	412LXR Ordering Information
<b>26-28</b>	Additional Products

## 400LXR Series Linear Motor Tables

Linear motors cannot function on their own. Before motion can occur, a platform must be engineered to provide support, direction, and feedback for the linear motor. Bearings, cables, connectors, encoder, travel stops, homing sensor and other components must be performance matched and integrated to achieve desired motion and control.

Parker linear motor tables provide all this and more in a pre-engineered, easily mounted, ready to run package. The linear motor magnet rail is mounted to a stationary base and the forcer is mounted to the moveable carriage. The only contact between the moving carriage and the stationary base is through the linear support bearings. High-precision square rail bearings provide load support, low-friction translation, and a precise linear path. A high resolution linear encoder provides the required velocity and positional information to the motor controller, and a unique cable management system enables high performance motion with a life of 30 million cycles and beyond.

Parker tables, with the slotless linear motor, are offered in three sizes: 404LXR, 406LXR, and 412LXR.

- Pre-engineered package
- Performance matched components
- Protection from environment
- Laser certified precision



### Performance Matched Components

The 400LXR Series linear servo motor tables achieve optimum performance by combining slotless motor technology with performance matched mechanical elements and feedback devices. Fast response, high acceleration, smooth translation, high velocity, and quick settling time describe the performance characteristics found in the 400LXR while high repeatability, precise accuracy, and sub-micron resolution define the positioning attributes.

### Sized to Fit

The 400LXR Tables are offered in three widths (100, 150, and 300 mm), and travel lengths up to 3 meters to accommodate the size and performance requirements of many industries including life sciences, photonics, semiconductor, digital printing, solar panel, and general automation.



### “Designer Friendly” Features and Options

A vast assortment of “designer friendly” features and options simplify the engineering challenges often confronted with “base model” positioning devices. Features like the IP30 protective strip seal and long life cable management system exemplify the built-in value found in the 400LXR units. Other selectable enhancements like cleanroom compatibility, travel limit sensors, motor drives, encoder resolution, and pinning holes for tooling location, simplify machine design and integration efforts.





## Flexibility and Multi-Axis Compatibility

The 400LXR's selection flexibility and mounting compatibility with the 400XR ballscrew driven tables enables single-axis or complex multi-axis units to be configured in a straightforward manner.

Parker's matching servo drives and motion controllers can be included to complete the motion system.



## Customs and Systems

For specialized applications requiring customization, Parker design engineers can easily modify these tables to suit, or engineer complete interactive linear motion systems to desired specifications.

Parker's 400LXR series tables have taken the mystery, difficulty and cost out of integrating linear motor tables into high throughput precision positioning applications.



Linear Motor Driven Tables

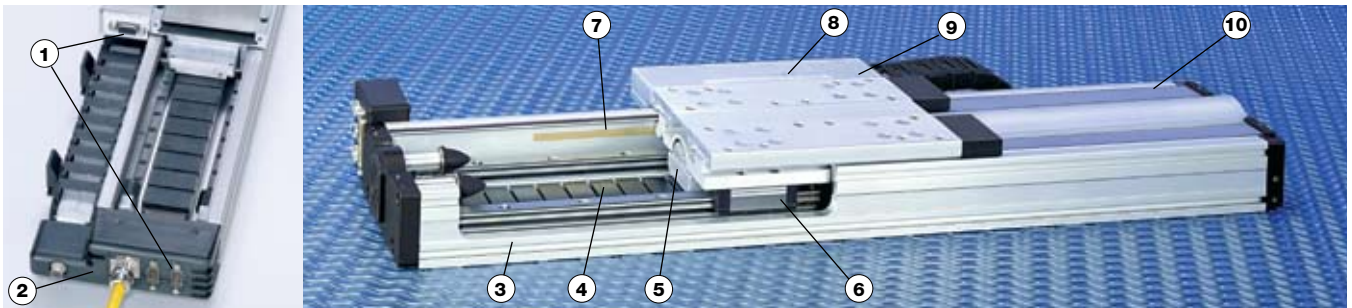

### 1 "Pass-Through" Cabling

Pre-wired, plug-in connection of the moving payload for easy hookup of user instruments or end effectors.

### 2 Connector Panel

Electrically shielded panel provides "plug-in" connectivity and quick disconnect for all signal and power requirements.

### 3 High Strength Aluminum Body

Extruded aluminum housing is precision machined to provide outstanding straightness and flatness.

### 4 Magnet Rail

Single rail of high energy rare earth magnets offers lower weight and lower cost than double magnet type.

### 5 Slotless Linear Motor

Provides a highly responsive, zero backlash drive system. Slotless motors offer excellent heat management, durability, and have built-in thermal sensor and hall sensors.

### 6 Linear Guidance System

The highly engineered carriage and bearing system effectively counters the combined problematic effects of heat, high-speed and high acceleration.

### 7 Integral Linear Encoder

Protected non-contact feedback with selectable resolutions to 0.1 micron. Z channel is factory aligned to home sensor for precise homing.

### 8 Limit/Home Sensors

Proximity sensors establish end of travel and "home" location and are easily adjustable over entire length to restrict the travel envelope.

### 9 "Quick Change" Cabling

Innovative cable transport module offers extended life (30 million cycles) and a simple cable changing system for preventative maintenance.

### 10 Protective Seals

Hard shell aluminum cover combined with stainless steel strip seals provide IP30 protection to interior components as well as enhances overall appearance.



Model		404LXR	406LXR		412LXR
<b>Motor</b>		<b>8 Pole</b>	<b>8 Pole</b>	<b>12 Pole</b>	<b>12 Pole</b>
<b>Rated Load</b>	kg (lb)	45 (99)	180 (396)	180 (396)	950 (2090)
<b>Maximum Acceleration</b>		5 Gs			
<b>Maximum Velocity</b>	(m/sec)				
<b>Encoder Resolution:</b>					
0.1 µm		0.3	0.3	0.3	0.3
0.5 µm		1.5	1.5	1.5	1.5
1.0 µm		3.0	3.0	3.0	3.0
5.0 µm		3.0	3.0	3.0	3.0
Sine Output		3.0	3.0	3.0	3.0
<b>Positional Repeatability</b>					
<b>Encoder Resolution:</b>					
0.1 µm			± 1.0 µm		
0.5 µm			± 1.0 µm		
1.0 µm			± 2.0 µm		
5.0 µm			± 10.0 µm		
Sine Output			(Interpolation Dependent)		
<b>Peak Force</b>	N (lb)	180 (40)	225 (50)	330 (75)	1000 (225)
<b>Continuous Force</b>	N (lb)	50 (11)	75 (17)	110 (25)	355 (80)
<b>Carriage Mass</b>	(kg)	1.4	3.2	4.1	12.3

**Travel Dependent Specifications**

Travel (mm)	Accuracy* (µm)			Unit Weight (Kg)			
	Positional Resolution 0.1 0.5 1.0	5.0	Straightness & Flatness	404LXR 8-Pole	406LXR 8-Pole	406LXR 12-Pole	412LXR 12-Pole
50	6	16	6	4.4	8.7	11.1	–
100	7	17	6	4.8	–	–	–
150	8	18	9	5.2	10.3	13.4	41
200	10	20	10	5.6	–	–	–
250	12	22	12	6.0	12.6	14.1	45
300	14	24	13	6.4	–	–	–
350	16	26	15	6.8	13.3	15.7	49
400	18	28	16	7.2	–	–	–
450	20	30	18	–	14.8	17.2	–
500	21	31	19	8.0	–	–	–
550	23	33	21	–	16.4	18.7	–
600	25	35	22	8.9	–	–	–
650	26	36	24	–	17.9	20.2	61
700	28	38	25	9.7	–	–	–
750	29	39	27	–	19.4	21.8	–
800	31	41	29	10.6	–	–	67
850	32	43	30	–	20.9	23.3	–
900	33	44	32	11.5	–	–	–
950	34	44	33	–	22.5	–	–
1000	35	45	35	12.4	–	27.1	75
1050	37	47	36	–	–	–	–
1200	39	49	41	–	26.3	–	83
1350	42	52	45	–	–	30.9	–
1450	43	53	48	–	30.1	–	–
1500	44	54	50	–	–	–	95
1600	45	55	53	–	–	34.7	–
1700	46	56	56	–	33.9	–	–
1750	46	56	57	–	–	–	105
1850	47	57	60	–	–	38.6	–
1950	48	58	63	–	37.7	–	–
2000	48	58	65	–	–	–	113
2350	49	59	76	–	–	–	–
2500	50	60	80	–	–	–	133
2850	50	60	84	–	–	–	–
3000	50	60	84	–	–	–	153

\* Accuracy stated is at 20° C, utilizing slope correction factor provided

**Encoder Specifications**

Description	Specification
<b>Input Power</b>	5 VDC ±5% 150 mA
<b>Output (Incremental)</b>	Square wave differential line driver (EIA RS422) 2 channels A and B in quadrature (90°) phase shift.
<b>Reference (Z Channel)</b>	Synchronized pulse, duration equal to one resolution bit. Repeatability of position is unidirectional moving toward positive direction.

**Limit and Home Specifications**

Description	Specification
<b>Input Power</b>	+5 to +24 VDC 60 mA (20 mA per sensor)
<b>Output</b>	Output form is selectable with product: Normally Closed Current Sinking Normally Open Current Sinking Normally Closed Current Sourcing Normally Open Current Sourcing All types Sink or Source max of 50 mA
<b>Repeatability</b>	Limits: ±10 microns (unidirectional) Home: See Z channel specifications

**Hall Effect Specifications**

Description	Specification
<b>Input Power</b>	+5 to +24 VDC, 30 mA
<b>Output</b>	Open Collector, Current Sinking, 20 mA Max



## Cable Transport Module

The LXR's Cable Transport Module offers the convenience of "plug and play" connectivity for fast, easy table installation and "quick change" replacement. This system of cable management includes the highest quality high-flex ribbon cable with a life rating of 30 million cycles, a cable track with support brackets, a "quick change" carriage cartridge, and a plug-in connector panel housing. It also provides a "pass-through" connection and cabling for customer application. This transport module option is ideal for high throughput continuous duty requirements where downtime is not acceptable.



"Quick Change" Cartridge



Cable Extensions - Flying Leads Terminations



404LXR Cable Transport Module

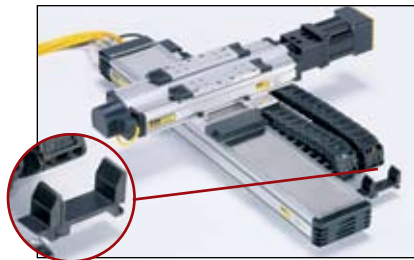

2-Axis System w/Expandable Cable Management



404LXR

406LXR/412LXR

### Cable Transport Module Order Code

Order Code	Extension Cable	
	Length (m)	Termination
CM02	No Extension Cables	
CM07	3.0	Flying Leads
CM08	7.5	Flying Leads
CM09	3.0	Gemini Conn.
CM10	7.5	Gemini Conn.
CM13	3.0	Aries/VIX Conn.
CM14	7.5	Aries/VIX Conn.

## OEM Cable System

The LXR's unharnessed cable system is offered for OEMs and others who have independent methods of routing and managing cables. These systems offer the "quick change" cartridge, "pass-through" connection and round high-flex cables in lengths of 3.0 or 7.5 meters. They are available with flying lead end terminations, as well as Gemini or Aries connectors.



406LXR with OEM cables and flying leads

### OEM Cable System Order Code

Order Code	Extension Cable	
	Length (m)	Termination
CM03	3.0	Flying Leads
CM04	7.5	Flying Leads
CM05	3.0	Gemini Conn.
CM06	7.5	Gemini Conn.
CM11	3.0	Aries/VIX Conn.
CM12	7.5	Aries/VIX Conn.

## User "Pass-Through" Cabling

Cable concerns regarding routing and durability for payload or instrument signals are addressed by the pass-through connectivity feature included with both of the LXR cable management systems. Nine pin D-connectors provided on the carriage (with the transport module units) and the cable connecting block combine with high-flex, long life cables for easy setup and dependable performance.

Note: Extension cables are available and can be ordered separately - 006-1743-01 (3 meters); 006-1743-02 (7.5 meters).

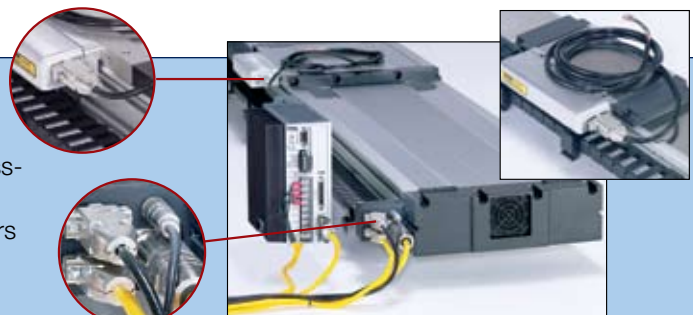

- Pre-wired plug-in connection to the moving payload
- Nine user conductors for end-effectors or instruments
- High-flex long life cables:
  - Ribbon Cable - Transport Module System
  - Round Cable - OEM System

**Simple Configuration Digital Drive Options**

All digital drives ordered in the LXR part number configuration come set up with a motor file including electrical parameters to set continuous and peak currents, current loop compensation values, and default gain settings. Users will have the ability to override these parameters for special application requirements. Tuning is easy to use and intuitive for users and is available via a variety of methods. The motor and loading information must be known by the drive to determine the baseline tuning gains. These are simple parameter entries the user can complete with the help of standard Parker supplied front-end software tools.

**Aries Series**



**Aries Digital Drive**

The Aries option allows the user to select the fully digital compact servo drive from Parker. Look for upcoming additions to the LXR configured with the Aries ETHERNET Powerlink version as well as the Aries Drive/Controller versions.

**Order Codes: A62 A63**

**Gemini Series**



**GV Digital Servo Drive**

The Gemini Series offers a fully digital servo drive configured directly in the LXR part numbering system.

**Order Codes: A4 A7 A40**

**GV Digital Controller/Servo Drive**

The Gemini Series servo drive/controller option allows the user to order a preconfigured digital drive/controller for a single-axis easy to use solution.

**Order Codes: A5 A6 A8 A9 A41 A42**

***For complete details on drive product features and specifications, please refer to the "Drives & Controllers" section of this catalog.***

**Dowel Pinning Options**

**Order Codes: P1 P2 P3**

Standard dowel pin locating holes P1 are offered on all 400LXR units to facilitate repeatable mounting of tooling or payload.

In addition, pinning options P2 and P3 are offered for precise orthogonal mounting of the second axis in a multi-axis system. In this case, the bottom side of the table base is match drilled and reamed to the first axis to provide exact orthogonal location. This convenient option eliminates concerns regarding contamination or damage often associated with machining for locating pins in an assembled unit. In some instances a 404LXR pinning adapter may be required part number 100-9584-01.



Two locating dowel holes, right (P1 option) shown in 404LXR carriage



## Cleanroom Preparation Option

**Order Codes: R2**

Cleanroom compatible linear tables are often required for laboratory and production applications in industries such as semiconductor, life science, electronics, and pharmaceuticals.

400LXR tables with cleanroom preparation were tested in Parker's vertical laminar flow work station, which utilizes ULPA filters to produce an environment having a cleanliness of class 1 prior to testing. Tables were tested in a variety of orientations with sampling both below the table and at the carriage mounting surface. Laminar flow rate is 0.65 inches W.C.

Special cleanroom testing can be provided upon request. For more information on cleanroom testing, contact a Parker Applications Engineer at 800-245-6903.



404LXR with cleanroom Class 10 modification

### About Cleanrooms

A room in which the concentration of airborne particles is controlled within defined limits. Federal Standard 209E statistically defines the allowable number of particles per cubic foot of air.

The chart below describes the conditions that must be maintained for the cleanroom to have a specific "class" rating.

Class	Number of Allowable Particles (Measured particle size in microns μm)				
	0.1	0.2	0.3	0.5	5
1	35	7.5	3	1	0
10	350	75	30	10	0
100	—	750	300	100	0
1000	—	—	—	1000	7
10000	—	—	—	10000	70
100000	—	—	—	100000	700

### Standard Cleanroom Preparation

- Stringent cleaning and handling measures
- Cleanroom rated lubrication
- Strip seal replaced with hard shell cover



Testing at 4.5 inches below table

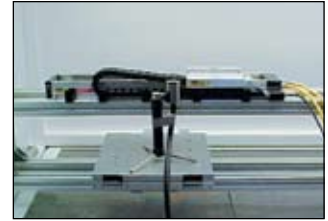

Testing at carriage mounting surface

### 400LXR Cleanroom Compatibility

Table Velocity	Class	
	4.5" Below Table	At Carriage Surface
250 mm/sec	10	1
500 mm/sec	25	1
1000 mm/sec	50	5
2000 mm/sec	250	25
3000 mm/sec	500	100

## Toe Clamp Accessories

**Part Number:** 100-8376-01 (404LXR)  
002-3624-01 (406LXR)  
002-2160-01 (412LXR)

Toe clamps for mounting 400LXR tables are ordered separately.

Note that 400LXR Series toe clamps are not interchangeable with toe clamps for 400XR Series tables.



Dimensions (mm)

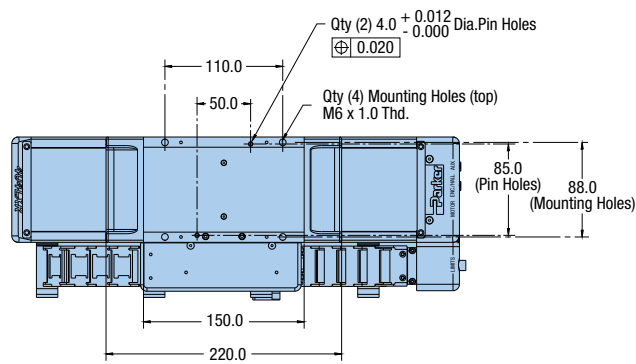

Top View  
(With Cable Transport Module)

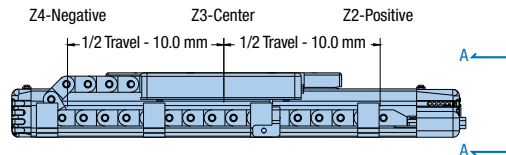

Front View  
Z-Channel Location

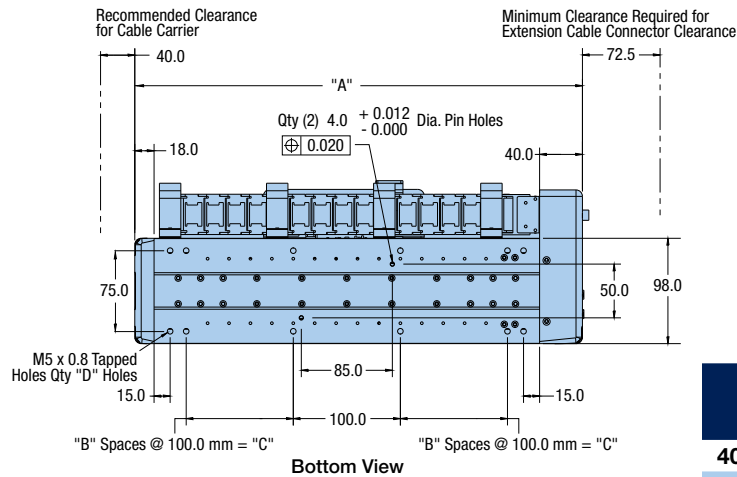

Bottom View

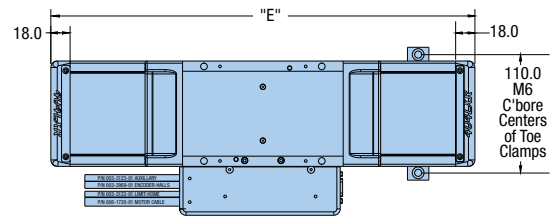

OEM Cables (Strip Seal/Hardcover)

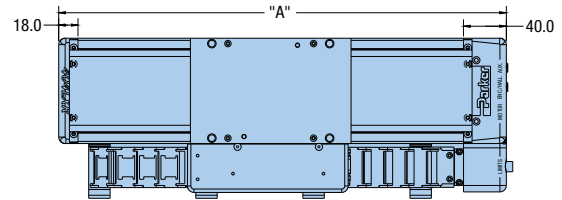

Cable Module (Strip Seal/Hardcover)

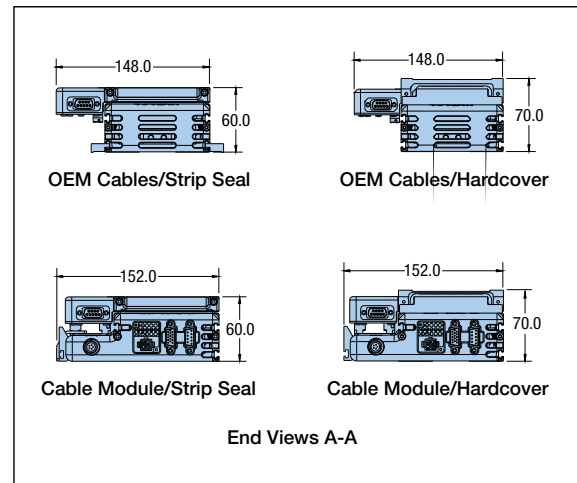

End Views A-A

Model	Travel (mm)	Dimensions (mm)				
		A	B	C	D	E
404T00LXR	50	368.0	1	100.0	12	346.0
404T01LXR	100	418.0	1	100.0	12	396.0
404T02LXR	150	468.0	1	100.0	12	446.0
404T03LXR	200	518.0	1	100.0	12	496.0
404T04LXR	250	568.0	1	100.0	12	546.0
404T05LXR	300	618.0	2	200.0	16	596.0
404T06LXR	350	668.0	2	200.0	16	646.0
404T07LXR	400	718.0	2	200.0	16	696.0
404T09LXR	500	818.0	3	300.0	20	796.0
404T11LXR	600	918.0	3	300.0	20	896.0
404T13LXR	700	1018.0	4	400.0	24	996.0
404T15LXR	800	1118.0	4	400.0	24	1096.0
404T17LXR	900	1218.0	5	500.0	28	1196.0
404T19LXR	1000	1318.0	5	500.0	28	1296.0





Fill in an order code from each of the numbered fields to create a complete model order code.

	①	②	③	④	⑤	⑥	⑦	⑧	⑨	⑩	⑪	⑫	⑬	⑭
<b>Order Example:</b>	404	T04	LXR	M	P	D13	H3	L2	CM09	Z2	E2	R1	A4	P1

Linear Motor Driven Tables

- ① **Series**  
404
- ② **Travel – mm**  
**8 Pole Motor**  
T00 50  
T01 100  
T02 150  
T03 200  
T04 250  
T05 300  
T06 350  
T07 400  
T09 500  
T11 600  
T13 700  
T15 800  
T17 900  
T19 1000
- ③ **Model**  
LXR Linear Motor
- ④ **Mounting**  
M Metric
- ⑤ **Grade**  
P Precision
- ⑥ **Drive Type**  
D3 Free Travel (No Motor)  
D13 8 Pole Motor
- ⑦ **Home Sensor**  
H1 None-Free Travel (only)  
H2 N.C. Current Sinking  
H3 N.O. Current Sinking  
H4 N.C. Current Sourcing  
H5 N.O. Current Sourcing
- ⑧ **Limit Sensor**  
L1 None-Free Travel (only)  
L2 N.C. Current Sinking  
L3 N.O. Current Sinking  
L4 N.C. Current Sourcing  
L5 N.O. Current Sourcing
- ⑨ **Cable Management**  
CM01 No Cables – Free Travel  
CM02 Cable Transport Module (only)  
CM03 3.0 m OEM Cable Set-FL  
CM04 7.5 m OEM Cable Set-FL  
CM05 3.0 m OEM Cable Set-Gemini  
CM06 7.5 m OEM Cable Set-Gemini  
CM07 Cable Trans Mod. w/3.0 m-FL\*  
CM08 Cable Trans Mod. w/7.5 m-FL\*  
CM09 Cable Trans Mod. w/3.0 m-Gemini\*  
CM10 Cable Trans Mod. w/7.5 m-Gemini\*  
CM11 3.0 m OEM Cable Set-Aries/ViX  
CM12 7.5 m OEM Cable Set-Aries/ViX  
CM13 Cable Trans Mod. w/3.0 m-Aries/ViX\*  
CM14 Cable Trans Mod. w/7.5 m-Aries/ViX\*  
\* Extension cable for pass through connection is available and can be ordered separately: #006-1743-01 (3 meters); #006-1743-02 (7.5 meters)
- ⑩ **Z Channel Location\***  
Z1 None  
Z2 Positive End Position  
Z3 Center Position  
Z4 Negative End Position  
\* Refer to dimensions on previous page
- ⑪ **Encoder Option**  
E1 None  
E2 1.0 µm Resolution  
E3 0.5 µm Resolution  
E4 0.1 µm Resolution  
E5 5.0 µm Resolution  
E7 Sine Output Encoder
- ⑫ **Environmental**  
R1 Strip Seal  
R2 Hard Cover w/Class 10 Cleanroom Prep  
R3 Hard Cover without Cleanroom Prep
- ⑬ **Digital Drive**  
A1 No Drive  
A4 Gemini Drive GV-U6E  
A5 Gemini Controller/Drive GV6-U6E  
A6 Gemini Controller/Drive GV6K-U6E  
A62 Aries Drive AR-04AE
- ⑭ **Pinning Option**  
P1 No multi-axis pinning  
P2 \* X axis transfer pinning to Y or Z axis - 30 arc-sec  
P3 \* Y axis transfer pinning to X axis - 30 arc-sec  
\* Transfer pinning to XR from LXR requires additional bracket and an EPS request. Call 1-800-245-6903 for details.



8 or 12 Pole Slotless Motor

Dimensions (mm)

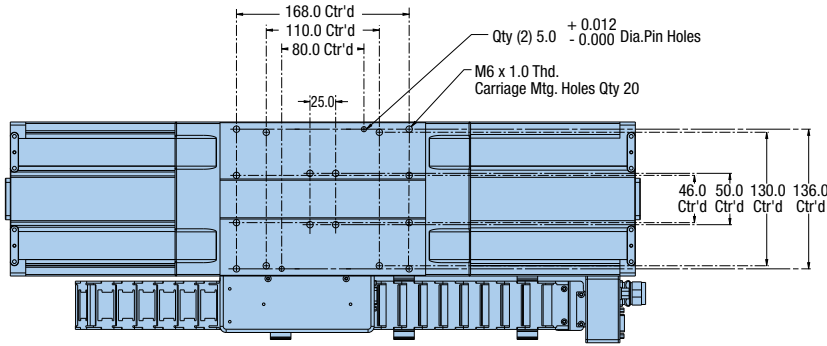

Top View  
(with Cable Transport Module)

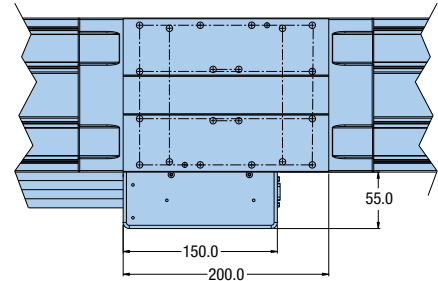

Top View  
(with OEM Cable System)

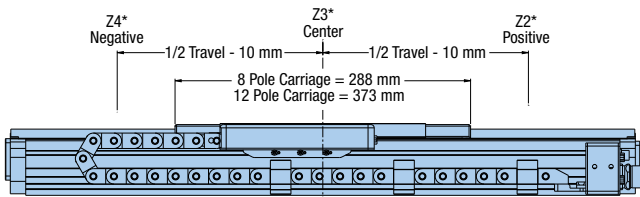

Front View  
(Z-Channel Location)

\*Z2, Z3, Z4 shows Carriage Center-line Location for Selected Z-Channel Position

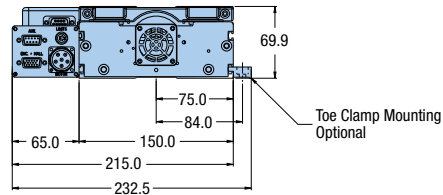

End View  
(with OEM Cable System)

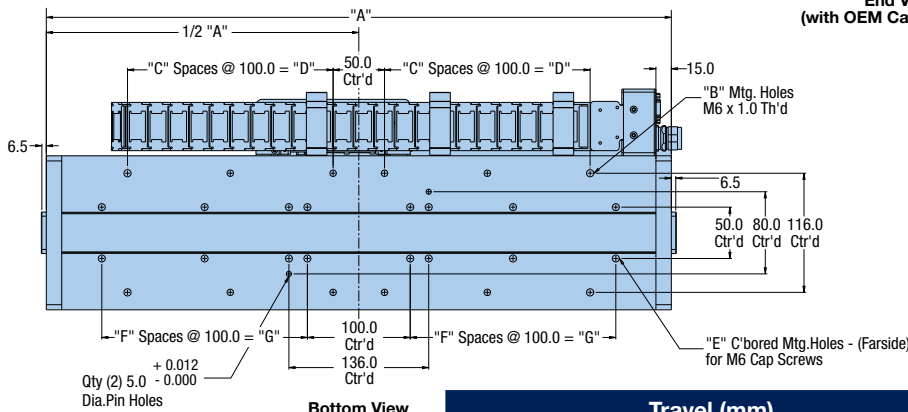

Bottom View

Model	Travel (mm)		Dimensions (mm)						
	8 Pole	12 Pole	A	B	C	D	E	F	G
406T01LXR	50	—	408	8	1	100.0	12	1	100.0
406T02LXR	150	50	508	8	1	100.0	12	1	100.0
406T03LXR	250	150	608	12	2	200.0	16	2	200.0
406T04LXR	350	250	708	12	2	200.0	16	2	200.0
406T05LXR	450	350	808	16	3	300.0	20	3	300.0
406T06LXR	550	450	908	16	3	300.0	20	3	300.0
406T07LXR	650	550	1008	20	4	400.0	24	4	400.0
406T08LXR	750	650	1108	20	4	400.0	24	4	400.0
406T09LXR	850	750	1208	24	5	500.0	28	5	500.0
406T10LXR	950	850	1308	24	5	500.0	28	5	500.0
406T11LXR	1200	1100	1558	32	7	700.0	32	6	600.0
406T12LXR	1450	1350	1808	36	8	800.0	40	8	800.0
406T13LXR	1700	1600	2058	40	9	900.0	44	9	900.0
406T14LXR	1950	1850	2308	44	10	1000.0	48	10	1000.0



Fill in an order code from each of the numbered fields to create a complete model order code.

	①	②	③	④	⑤	⑥	⑦	⑧	⑨	⑩	⑪	⑫	⑬	⑭
<b>Order Example:</b>	406	T08	LXR	M	P	D13	H2	L2	CM09	Z2	E2	R1	A4	P1

- ① **Series**  
406
- ② **Travel – mm**

	8 Pole Motor	12 Pole Motor
T01	50	—
T02	150	50
T03	250	150
T04	350	250
T05	450	350
T06	550	450
T07	650	550
T08	750	650
T09	850	750
T10	950	850
T11	1200	1100
T12	1450	1350
T13	1700	1650
T14	1950	1850
- ③ **Model**  
LXR Linear Motor
- ④ **Mounting**  
M Metric
- ⑤ **Grade**  
P Precision
- ⑥ **Drive Type**

**Free Travel (No Motor)**

D3 8 Pole Motor (No Motor)  
D5 12 Pole Motor (No Motor)

**Linear Motor**

D13 8 Pole Motor Carriage  
D15 12 Pole Motor Carriage
- ⑦ **Home Sensor**

H1 None-Free Travel (only)  
H2 N.C. Current Sinking  
H3 N.O. Current Sinking  
H4 N.C. Current Sourcing  
H5 N.O. Current Sourcing
- ⑧ **Limit Sensor**

L1 None-Free Travel (only)  
L2 N.C. Current Sinking  
L3 N.O. Current Sinking  
L4 N.C. Current Sourcing  
L5 N.O. Current Sourcing
- ⑨ **Cable Management**

CM01 No Cables – Free Travel  
CM02 Cable Transport Module (only)  
CM03 3.0 m OEM Cable Set-FL  
CM04 7.5 m OEM Cable Set-FL  
CM05 3.0 m OEM Cable Set-Gemini  
CM06 7.5 m OEM Cable Set-Gemini  
CM07 Cable Trans Mod. w/3.0 m-FL\*  
CM08 Cable Trans Mod. w/7.5 m-FL\*  
CM09 Cable Trans Mod. w/3.0 m-Gemini\*  
CM10 Cable Trans Mod. w/7.5 m-Gemini\*  
CM11 3.0 m OEM Cable Set-Aries/ViX  
CM12 7.5 m OEM Cable Set-Aries/ViX  
CM13 Cable Trans Mod. w/3.0 m-Aries/ViX\*  
CM14 Cable Trans Mod. w/7.5 m-Aries/ViX\*

\* Extension cable for pass through connection is available and can be ordered separately: #006-1743-01 (3 meters); #006-1743-02 (7.5 meters)
- ⑩ **Z Channel Location\***

Z1 None  
Z2 Positive End Position  
Z3 Center Position  
Z4 Negative End Position

\* Refer to dimensions on previous page
- ⑪ **Encoder Option**

E1 None  
E2 1.0 µm Resolution  
E3 0.5 µm Resolution  
E4 0.1 µm Resolution  
E5 5.0 µm Resolution  
E7 Sine Output Encoder
- ⑫ **Environmental**

R1 Strip Seal  
R2 Hard Cover w/Class 10 Cleanroom Prep
- ⑬ **Digital Drive**

A1 No Drive  
A4 Gemini Drive GV-U6E  
A5 Gemini Controller/Drive GV6-U6E  
A6 Gemini Controller/Drive GV6K-U6E  
A62 Aries Drive AR-04AE
- ⑭ **Pinning Option**

P1 No multi-axis pinning  
P2 \* X axis transfer pinning to Y or Z axis - 30 arc-sec  
P3 \* Y axis transfer pinning to X axis - 30 arc-sec

\* Transfer pinning to XR from LXR requires additional bracket and an EPS request. Call 1-800-245-6903 for details.

12 Pole Slotless Motor

Dimensions (mm)

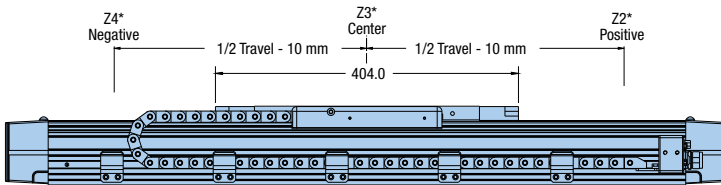
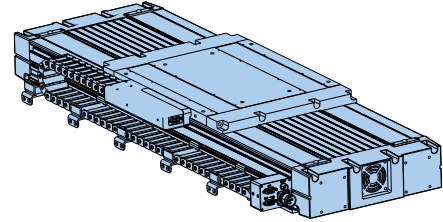
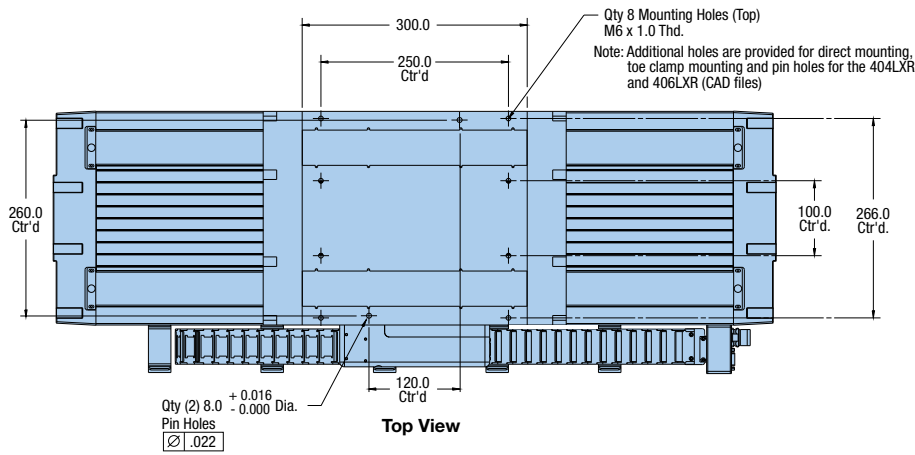

\*Z2, Z3, Z4 shows Carriage Center-line Location for Selected Z-Channel Position

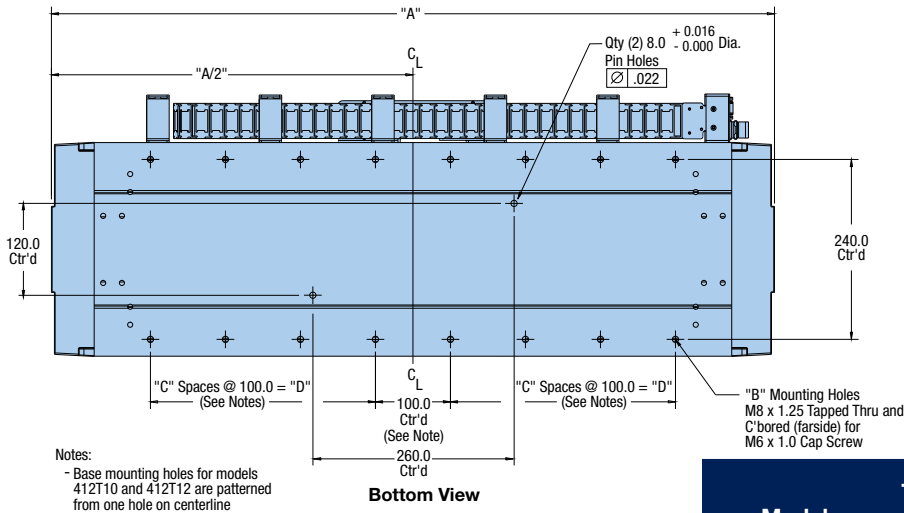
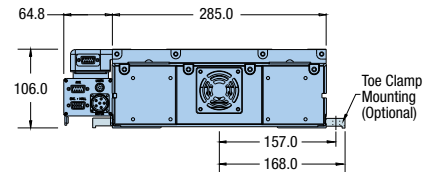

Model	Travel (mm)	Dimensions (mm)			
		A	B	C	D
412T01LXR	150	764	12	2	200
412T02LXR	250	864	16	3	300
412T03LXR	350	964	16	3	300
412T04LXR	650	1264	24	5	500
412T05LXR	800	1414	24	5	500
412T06LXR	1000	1614	28	6	600
412T07LXR	1200	1814	32	7	700
412T08LXR	1500	2114	40	9	900
412T09LXR	1750	2364	44	10	1000
412T10LXR	2000	2614	50	12	1200
412T11LXR	2500	3114	60	14	1400
412T12LXR	3000	3614	70	17	1700



Fill in an order code from each of the numbered fields to create a complete model order code.

① ② ③ ④ ⑤ ⑥ ⑦ ⑧ ⑨ ⑩ ⑪ ⑫ ⑬ ⑭

**Order Example:** 412 T09 LXR M P D15 H3 L3 CM09 Z2 E2 R1 A7 P1

① **Series**  
412

② **Travel – mm**  
**8 Pole Motor**

T01	150
T02	250
T03	350
T04	650
T05	800
T06	1000
T07	1200
T08	1500
T09	1750
T10	2000
T11	2500
T12	3000

③ **Model**  
LXR Linear Motor

④ **Mounting**  
M Metric

⑤ **Grade**  
P Precision

⑥ **Drive Type**  
D5 Free Travel (No Motor)  
D15 12 Pole Motor

⑦ **Home Sensor**  
H1 None-Free Travel (only)  
H2 N.C. Current Sinking  
H3 N.O. Current Sinking  
H4 N.C. Current Sourcing  
H5 N.O. Current Sourcing

⑧ **Limit Sensor**  
L1 None-Free Travel (only)  
L2 N.C. Current Sinking  
L3 N.O. Current Sinking  
L4 N.C. Current Sourcing  
L5 N.O. Current Sourcing

⑨ **Cable Management**

CM01 No Cables – Free Travel  
 CM02 Cable Transport Module (only)  
 CM03 3.0 m OEM Cable Set-FL  
 CM04 7.5 m OEM Cable Set-FL  
 CM05 3.0 m OEM Cable Set-Gemini  
 CM06 7.5 m OEM Cable Set-Gemini  
 CM07 Cable Trans Mod. w/3.0 m-FL\*  
 CM08 Cable Trans Mod. w/7.5 m-FL\*  
 CM09 Cable Trans Mod. w/3.0 m-Gemini\*  
 CM10 Cable Trans Mod. w/7.5 m-Gemini\*  
 CM11 3.0 m OEM Cable Set-Aries/ViX  
 CM12 7.5 m OEM Cable Set-Aries/ViX  
 CM13 Cable Trans Mod. w/3.0 m-Aries/ViX\*  
 CM14 Cable Trans Mod. w/7.5 m-Aries/ViX\*

\* Extension cable for pass through connection is available and can be ordered separately: #006-1743-01 (3 meters); #006-1743-02 (7.5 meters)

⑩ **Z Channel Location\***

Z1 None  
 Z2 Positive End Position  
 Z3 Center Position  
 Z4 Negative End Position

\* Refer to dimensions on previous page

⑪ **Encoder Option**

E1 None  
 E2 1.0 µm Resolution  
 E3 0.5 µm Resolution  
 E4 0.1 µm Resolution  
 E5 5.0 µm Resolution  
 E7 Sine Output Encoder

⑫ **Environmental**

R1 Strip Seal  
 R2 Hard Cover w/Class 10 Cleanroom Prep

⑬ **Digital Drive**

A1 No Drive  
 A7 Gemini Drive GV-U6E  
 A8 Gemini Controller/Drive GV6-U6E  
 A9 Gemini Controller/Drive GV6K-U6E  
 A63 Aries Drive AR-04AE

⑭ **Pinning Option**

P1 No multi-axis pinning  
 P2 \* X axis transfer pinning to Y or Z axis - 30 arc-sec  
 P3 \* Y axis transfer pinning to X axis - 30 arc-sec

\* Transfer pinning to XR from LXR requires additional bracket and an EPS request. Call 1-800-245-6903 for details.

**Trilogy I-Force Ironless Linear Motors**

[www.parker.com/em/ironless](http://www.parker.com/em/ironless)



Parker Trilogy's I-Force ironless motors offer high force and rapid accelerations in a compact package. Parker Trilogy's patented I-beam shape, with its overlapping windings, allows for a higher power density in a smaller motor, improved heat removal, and added structural stiffness. A forgiving air gap and no attractive forces allow for easy installation and zero cogging during motion.

- 5 different cross sections (110, 210, 310, 410, and ML50) up to 8 poles
- Compact size with high force density and superior heat removal
- Air and water cooling
- Vacuum rated to 10<sup>-6</sup> torr
- Ultra high-flex cable standard

**Trilogy RIPPED Ironcore Linear Motors**

[www.parker.com/em/ironcore](http://www.parker.com/em/ironcore)



Parker Trilogy's RIPPED ironcore linear motors, with their patent-pending anti-cog technology, can produce the large forces needed for many industrial applications – without the roughness associated with traditional ironcore linear motors. The RIPPED family is well suited for a broad range of extremely demanding applications.

- Patent-pending anti-cog technology for extremely smooth motion
- 5 different cross sections
- Single magnet row for high performance at an economical price
- Connector module allows for quick installation and easy cable management
- Ultra high-flex cable standard

**Trilogy ML50 Ironless Linear Motors**

[www.parker.com/em/ML50](http://www.parker.com/em/ML50)



Parker Trilogy's ML50 ironless linear motors are optimized to provide high forces with minimum moving mass, making them the ideal choice for applications requiring very

high, continuous accelerations of relatively light payloads. Demanding applications such as high-speed pick and place, die sorting, injection mold loading/unloading, and textile weaving can all benefit from unique characteristics of the ML50 motors.

- Optimized for ultra high acceleration of light payloads
- Compact size with high force density and superior heat removal
- Connector module for quick installation and easy cable management
- Ultra high-flex cable standard

Series	I-Force Ironless	ML50 Ironless	Ripped Ironcore
<b>Continuous force</b>	5.5 to 197.5 lbf (24.5 to 878.6 N)	43 to 192 lbf (189 to 852 N)	13 to 501 lbf (56 to 2230 N)
<b>Peak force</b>	45.5 to 883 lbf (202.5 to 3928 N)	190 to 857 lbf (847 to 3811 N)	43 to 1671 lbf (190 to 7433 N)
<b>Cogging force</b>	Zero	Zero	Low
<b>Attractive force</b>	Zero	Zero	High
<b>Magnet tracks</b>	Dual	Dual	Single
<b>Heat dissipation</b>	Good	Good	Better
<b>Applications</b>	Rapid accelerations, extremely smooth motion	Ultra high accelerations of relatively light payloads	High force, lower cost for long travels



## Trilogy Ironless and Ironcore Linear Motor Positioning Tables

[www.parker.com/em/lmpositioners](http://www.parker.com/em/lmpositioners)

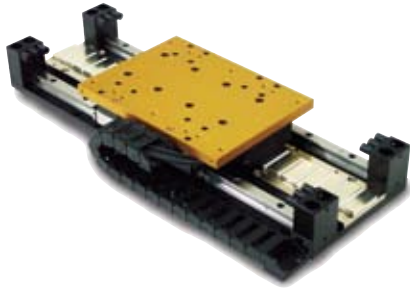

Parker linear positioners utilize our high-performance Trilogy ironless and ironcore linear motors in a pre-engineered, easily integrated, ready-to-run package. The principal design goal for these positioners is to achieve high performance at an economical cost while preserving the design flexibility to accommodate customization. Options include multi-axis configurations, bellows, and a variety of cable management systems.

- Single- or dual-bearing rail positioners to better match the performance and cost requirements for each application
- Magnetic encoders for industrial environments or optical encoders with resolutions down to 0.1 micron
- Multiple carriage options
- Open frame, bellows or two covers available
- Zero cogging (ironless) or extremely smooth (ironcore)
- Counterbalance options for vertical applications
- Velocities to 7 m/s



Linear Motor Driven Tables

*For more information on these Trilogy products, refer to our complete Linear Motor Catalog #96-028778-01.*

Series	T1S / T1D	T2S / T2D	T3S / T3D	T4S / T4D	TR7	TR9	TR16
<b>Motor</b>	110 ironless	210 ironless	310 ironless	410 ironless	R7 ironcore	R9 ironcore	R16 ironcore
<b>Travel lengths (mm)</b>	100 to 900	60 to 3840	60 to 4390	78 to 3835	105 to 2745	108 to 3708	94 to 3694
<b>Load (kg)</b>	11.3*/13.5**	27.2*/45.3**	72*/108**	90*/181**	200**	300**	450**
<b>Acceleration (G's) ***</b>	5	5	5	5	5	5	5
<b>Velocity (m/s) †</b>	up to 3	up to 5	up to 5	up to 5	up to 5	up to 5	up to 5
<b>Peak force (N)</b>	202.5	494.2	1170.0	3928.1	1761.0	4097.0	7433.0
<b>Continuous force (N)</b>	45.4	110.3	262.0	878.6	462.0	1121.0	2230.0
<b>Resolution (micron)</b>	0.1 to 5.0	0.1 to 5.0	0.1 to 5.0	0.1 to 5.0	0.1 to 5.0	0.1 to 5.0	0.1 to 5.0
<b>Repeatability (micron) ‡</b>	±1	±1	±1	±1	±1	±1	±1

\* Single rail load specifications

\*\* Dual rail load specifications

\*\*\* Consult factory for higher accelerations

† Peak velocity is encoder dependent

‡ Repeatability is resolution dependent

Recommended loads based on motor size and typical performance.

Bearing specifications exceeded listed specifications. Consult factory for higher loads.

**RD Direct Drive Rotary Stages**

[www.parkermotion.com/products](http://www.parkermotion.com/products)



Parker Direct Drive Rotary Stages feature a robust construction and high performance in a compact package, providing smooth, near frictionless motion with zero backlash.

Featuring an integral brushless DC servo motor, these rotary stages offer several distinct advantages over traditional worm gear-driven stages. The elimination of the worm gearing offers the ability to reduce wear with zero backlash while exhibiting near frictionless motion.

Its high positioning accuracy, solely based on the stage's encoder, provides repeatability within 2 encoder counts, with resolutions ranging to 1.4 arc-seconds. The RD Direct Drive features speeds up to 700 RPM with significant torque capability.

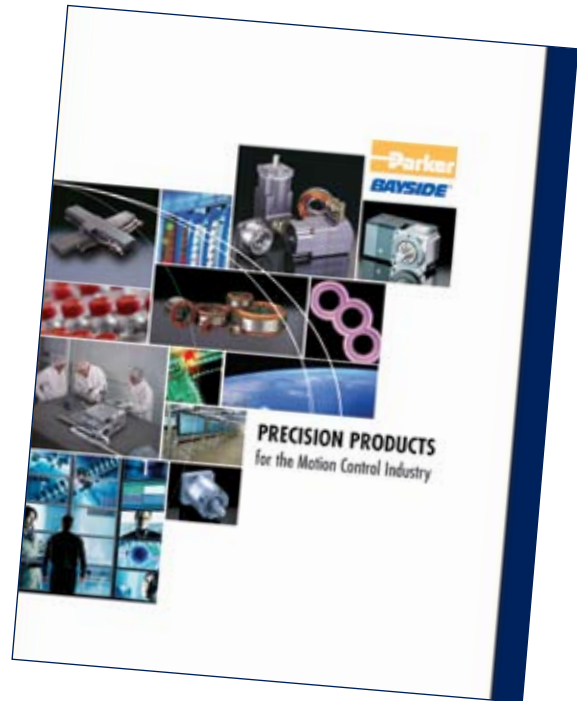

*For more information on Parker's direct drive rotary products, please refer to catalog 8100.*

**Applications**

- Electronic assembly
- Fiber Optics
- Medical
- Packaging
- Pharmaceutical

**Recommended Uses**

- Precision rotary motion
- ZERO backlash
- Compact
- Rugged

**Unique design integrated brushless motor features high copper slot and rare earth magnet for maximum torque efficiency**

**Aluminum or stainless steel precision ground top plate for accurate mounting**

**Robust bearing design for high load capacity**

**Sub "D" connectors for "plug & play" operation and easy hook-up.**

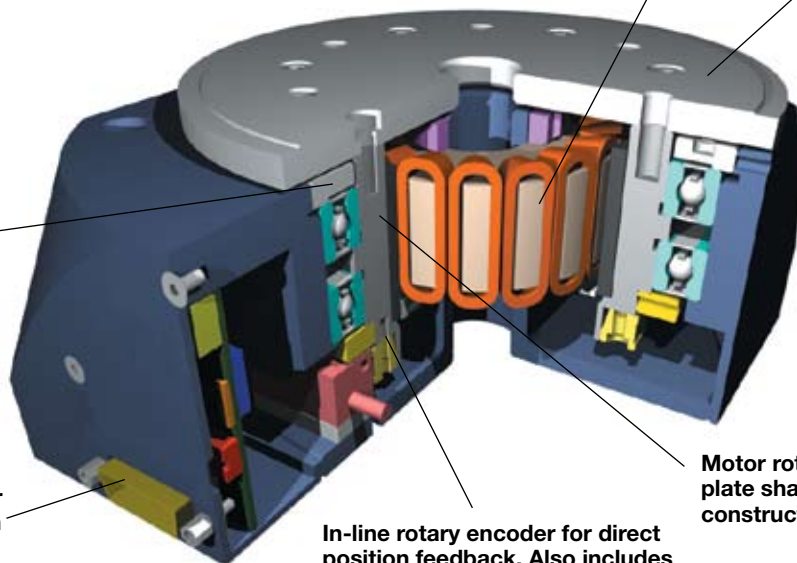

**In-line rotary encoder for direct position feedback. Also includes once per rev index mark**

**Motor rotor and top plate shaft as one-piece construction for high stiffness**